

# DH Dual Hall Effect Pickup

## Installation and Technical Data Guide

Rev 06/06

### Description:

The DH Dual Hall Effect Pickups are microprocessor-based sensors for use with the JV-CG and JV-KG series of positive displacement flow meters. The DH sensors can detect both uni- and bi-directional flow. The sensors' mode of operation is determined by an output selection switch located inside the housing. The DH detects the rotation of the flow meter's gears and emits a frequency signal proportional to flow. The output signal is a square wave pulse which has a duty cycle of approximately 50%.

DH signal outputs are protected with a self-resetting fuse. This fuse has a 50mA nominal trip point. When a trip occurs, turn off power to the sensor and remove output load to reset fuse. The sensor has two different output configurations: sinking output and sourcing output.

The DH sensor circuit board is equipped with a red and green LED. The red LED is a status LED which, when the sensor is operating properly, will flash once every 6 seconds, a fast flash will indicate a failure of one or both of the pick-ups. The green LED indicates the pulse of the input signal. Note that signals above 20Hz will look as solid green.

### Installation:

- Ensure that the flowmeter sensor cavity is free of debris prior to installing pickup
- Make sure the sensor mounting screws line up with the sensor mounting holes. If they do not, remove and rotate the sensor 180°
- Sensor is equipped with an output test feature for readouts before initial running of your system

### TEST FEATURE: **Note: Power must be cycled for new setting to take effect**

- Switch setting 8 will cause the pick-up to output a 10 Hz (+/- 20%) Phase = +90 deg pulse output, simulating low flow conditions without flow through your meter.
- Switch setting 9 will cause the pick-up to output a 250 Hz (+/- 20%) Phase = -90 deg pulse output, simulating medium flow conditions without flow through your meter.

**NOTE: WIRING SHOULD BE INSTALLED BY A QUALIFIED INSTRUMENTATION TECHNICIAN**

### Electrical Connection for Pin Connector

Pin Number	DH-A / -AA	DH-B / -BB
1	NC	NC
2	Output 2	Output 2
3	NC	NC
4	Output 1	Output 1
5	Ground	Ground
6	Supply	Supply

### AW Company wiring color code:

	Pin Number	Wire Color
Signal 2:	2	Green
Signal 1:	4	White
Ground:	5	Black
<b>Supply Voltage:</b>	<b>6</b>	<b>Red</b>

### DH Operating Modes

Switch	Output 1	Output 2
0	Direction	Signal 2
1	Signal 1	Signal 2
2	Direction	Signal 1 + 2 (2x frequency)
3	Signal 1	Signal 1 + 2 (2x frequency)
4	Signal 1 (both outputs in phase)	
5	Signal 2 (both outputs in phase)	
6	Signal 1 + 2 (both 2x frequency & both outputs in phase)	
7	Reserved	
8	Test: S1 & S2 == 10 Hz (+/- 20%) Phase = +90 deg.	
9	Test: S1 & S2 == 250 Hz (+/- 20%) Phase = -90 deg.	

**Note: Power must be cycled for new setting to take effect**

Pinout looking at male connector on sensor

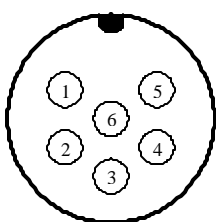

Top view of circuit board with view of LED's and switch

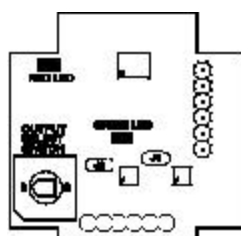

# DH Dual Hall Effect Pickup

## Installation and Technical Data Guide

Rev 06/06

### Technical Data:

Supply Voltage:	+10 to 27 Volt DC
Supply Current:	18 mA @ 12 VDC, 25 mA @ 24 VDC
Duty Signal:	50% ± 15%
Minimum Signal:	0.5 Hz
Frequency Output:	Flow dependent, up to 2,000 Hz
Driving Capacity:	50 mA Max resistive load
Output Impedance:	~ 40 Ohm - analog switch and self-resetting fuse
Temperature Range:	-40° F to 185° F (-40° C to 85° C)

### Part number configuration:

DH Sensors can be used with all Aluminum, 303 Stainless Steel and 316 Stainless Steel body flow meters

JV-CG 01, 10, 15, 20 & 30 |———— DH-A, DH-B  
JV-KG 12, 20 & 30

JV-60CG & JV-60KG **ONLY** |———— DH-AA, DH-BB

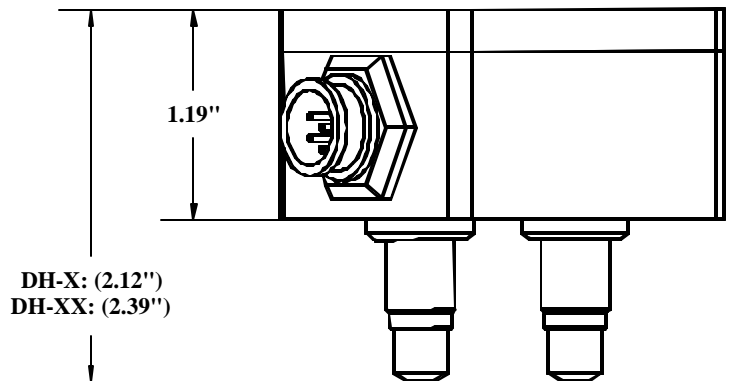

### DH-A / -AA Sinking Output Circuit

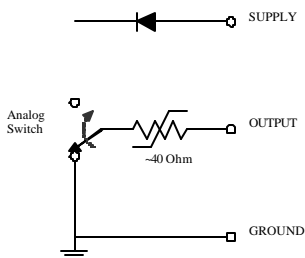

- User may need to add external components to interface to displays or other instruments
- User must limit output voltage to Supply -1V
- Max current sinking capability: 50mA

### DH-B / -BB Sourcing Output Circuit

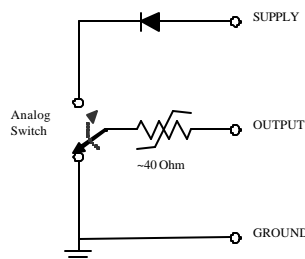

- Signal output square wave :  
 $V_{high} = \text{Supply} - 1V$  @ no output load  
 $V_{low} = 0.1V$
- Max sourced output voltage: Supply -0.5V
- Max current sourcing capabilities: 50mA