

# Hall-4 Pickup

Rev 10/06

## Installation and Technical Data Guide

### Description:

The Hall-4 is a frequency multiplying sensor, typically used at the low flow range of flow meters to produce more resolution. The Hall-4 generates 1x, 2x, 5x or 10x the number of pulses compared to standard sensors.

The Hall-4 sensor is compatible with JV-CG, JV-KG, HPM and with select ZHM and SRZ flow meters - **contact AW Company for model compatibility**. The sensor detects the rotation of the flow meter gears and emits a frequency signal proportional to flow. The output signal is a square wave pulse which has a duty cycle of either 50% or 500 us. depending on multiplier settings.

The Hall-4 signal output is protected with a self-resetting fuse. This fuse has a 50mA nominal trip point. When a trip occurs, turn off power to the sensor and remove output load to reset fuse. The sensor has two different output configurations: sinking output and sourcing output.

The Hall-4 sensor circuit board is equipped with a red and green LED. The red LED is a status LED which, when the sensor is operating properly, will flash once every 4 seconds, a fast flash will indicate a failure of the pick-up. The green LED indicates the pulse of the input signal. Note that signals above 20Hz will look as solid green.

### Installation:

- Ensure that the flowmeter sensor cavity is free of debris prior to installing pickup
- Install flow meter and sensor - **CYCLE POWER** - or sensor will not function properly!!
- An internal jumper determines if sensor output is sinking or sourcing
- Sensor is equipped with an output test feature to test for readouts before initial running of your system

### Test Feature: Note: Power must be cycled for new setting to take effect

- Switch setting 8 will cause the pick-up to output a 10 Hz (-/+ 20%) 50% duty cycle output, simulating low flow conditions without flow through the meter.
- Switch setting 9 will cause the pick-up to output a 250 Hz (+/- 20%) 500 us pulse output, simulating medium flow conditions without flow through the meter.

**NOTE: WIRING SHOULD BE INSTALLED BY A QUALIFIED INSTRUMENTATION TECHNICIAN**

### Electrical Connection for Pin Connector

Pin Number	Function
1	NC
2	NC
3	NC
4	Output
5	Ground
6	Supply

Pinout looking at male connector on sensor

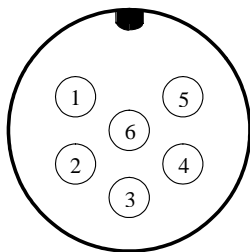

Top view of circuit board with view of LED's and switch

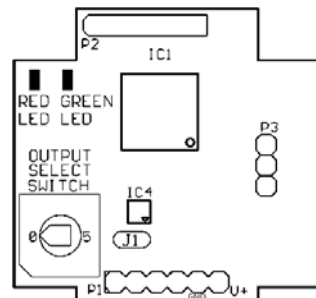

### AW Flow Meters Wiring Color Code

	Pin Number	Wire Color
Signal:	4	White
Ground:	5	Black
Supply Voltage:	6	Red

Switch	Output
0	Signal 1x frequency, 50% Duty Cycle
1	Signal 2x frequency, 500 us pulse
2	Reserved
3	Signal 5x frequency, 50% Duty Cycle
4	Reserved
5	Signal 10x frequency, 500 us pulse
6	Reserved
7	Reserved
8	Test: 10 Hz (+/- 20%) 50% Duty Cycle
9	Test: 250 Hz (+/- 20%) 500 us pulse

Note: Power must be cycled for new setting to take effect

# Hall-4 Pickup

Rev 10/06

## Installation and Technical Data Guide

Average height from flow meter to sensor top

Flow meter range	Average height
01 to 30	2 1/8"
60	1 7/8"

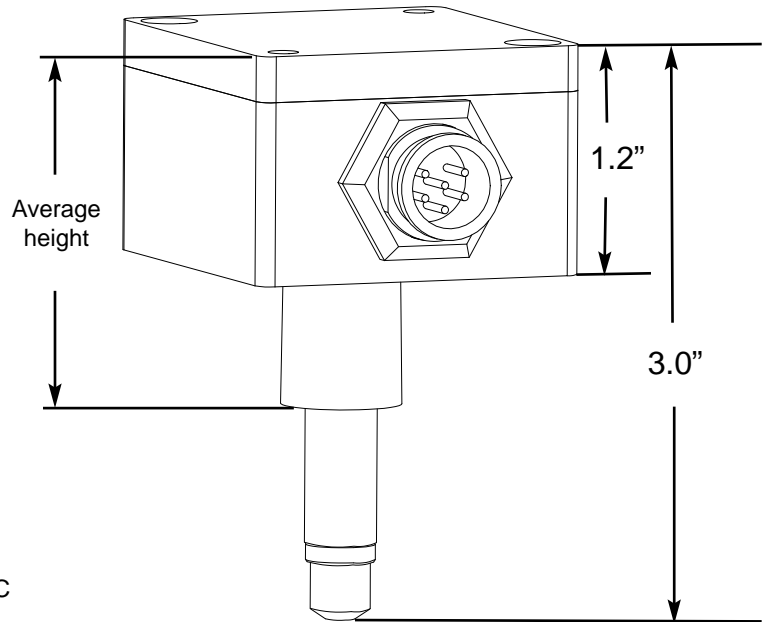

### Technical Data:

Supply Voltage:	+10 to 27 Volt DC			
Supply Current:	25 mA @ 12 VDC, 50mA @ 24 VDC			
Duty Signal:	50% ± 5% for multiplier 1 & 5			
	500 us pulse for multiplier 2 & 10			
Minimum Input Signal:	0.5 Hz			
Maximum input frequency:	1x	2x	5x	10x (multiplier)
	250	250	200	100 (frequency)
Frequency Output:	Flow dependent, up to 1,000 Hz			
Driving Capacity:	50 mA Max resistive load			
Output Impedance:	~ 40 Ohm - analog switch and self-resetting fuse			
Temperature Range:	-40° F to 160° F (-40° C to 70° C)			

Hall-4 sensors can be used with Aluminum, 303 Stainless Steel and 316 Stainless Steel body flow meters

A swivel fitting is required to mount Hall-4 pick-up on AW brand meters from AW-Lake Company.

### Sinking Output Circuit

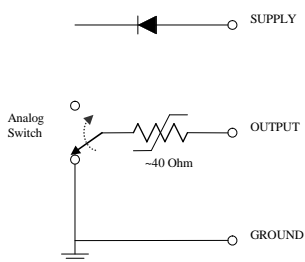

- Output jumper (J1) off
- User may need to add external components to interface to displays or other instruments
- User must limit output voltage to Supply -1V
- Max current sinking capability: 50mA

### Sourcing Output Circuit - Default from factory

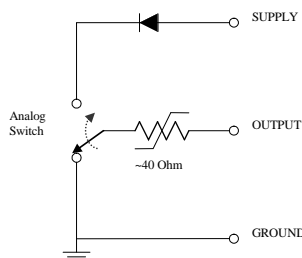

- Output jumper (J1) on
- Signal output square wave :  
 $V_{high} = \text{Supply} - 1V$  @ no output load  
 $V_{low} = 0.1V$
- Max sourced output voltage: Supply -0.5V
- Max current sourcing capabilities: 50mA