

IF Series Inductive Pickup with Amplifier

The IF series inductive pickup and VIEG amplifier are applied in high temperature applications beyond the normal operating range of standard magnetic pickups. The inductive sensor generates a sinusoidal output signal with an amplitude between 0.5mV to 0.5V. The VIEG is designed to amplify and shape this signal providing a square wave output voltage of 8V pp.

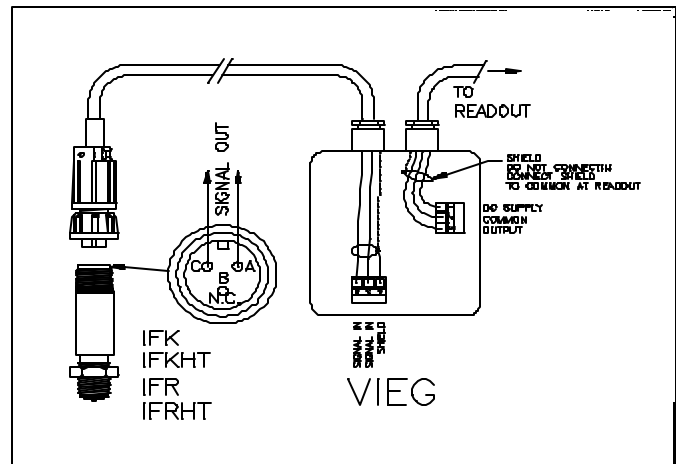

Application of the IF Series Inductive Pickups

The selection of an inductive pickup is recommended when the operating temperature exceeds 176°F/80° C. Operation can be expected up to 360°F/180°C with the standard version and up to 465°F/240°C using the HT version.

Because of the low signal levels involved, the following guidelines should be followed:

- Only use braided, shielded cable. The shield should only be connected at the amplifier module as indicated. The distance between the amplifier and sensor should not exceed 3 meters/10 feet.
- Because of the low signal levels, direct the electronics as far as possible from other electromagnetic field sources.
- The pickup should be inserted until hand tight, then turned back 1/4rev. Tighten the lock nut to secure this position.
- The meter can be mounted in any manner, however, every effort should be made to minimize vibrations. Strong vibrations can have a microphonic effect on the pickup sensor. Flexible connections will help to reduce pipeline vibrations considerably where this is a concern.

VIEG Technical Data

In: Voltage pulses of amplitudes 0.5mV - 0.5V. Impedance 100 Ohms.
 Out: 8V square wave pulse. Impedance 5.6K Ohms
 Supply: 7-29 Volts DC .5mA
 Dimensions: L=64mm; W=58mm; H=37mm
 Weight: 0.13lb.

Technical data:**Operating temp:****Supply voltage:****Current consumption:****Output:****Electrical data:****VIEG Amplifier**

-20°C to + 80°C

 U_B : 7 to 29V/DC $I_R < 4\text{mA}$

Square wave frequency output

Voltage level NPN/PNP (three-wire connection)

**A) Active output NPN**High level: $U_{\text{High}} > U_B - 0.6\text{V} - (2.6\text{k}\Omega \times I_{\text{out}})$ Low level: $U_{\text{Low}} > 0.6\text{V} + (1.3\text{k}\Omega \times I_{\text{out}})$ **B) Passive output NPN (OC-output)**High level: $U_{\text{High}} = U_B$ Low level: $U_{\text{Low}} < 0.6\text{V} + (1.3\text{k}\Omega \times I_{\text{out}})$ U_B is the applied voltage at the output. 29V max.**C) Active output PNP**High level: $U_{\text{High}} > U_B - 0.6\text{V} - (150\Omega \times I_{\text{out}})$ Low level: $U_{\text{Low}} = \text{cut off}$ **D) Passive output PNP (OC-output)**High level: $U_{\text{High}} > U_B - 0.6\text{V} - (150\Omega \times I_{\text{out}})$ Low level: $U_{\text{Low}} = \text{cut off}$ U_B is the applied voltage at the output. 29V max. $I_{\text{max}} = 60\text{mA}$; P_{max} on $R_s = 1\text{W}$; $R_s = 150\Omega$ **Current level (two-wire connection)**High level: $I_{\text{High}} > 2.2\text{mA}$ Low level: $I_{\text{low}} < 1.4\text{mA}$ **Input impedance:**

< 100Ω

Input:

0.5mV up to 0.5V

Frequency range:

7-3000 Hz according to flowmeter type

Electrical connection:

Terminals 1, 2, 3 for supply voltage, ground & signal outlet

Terminals 4, 5, 6 for shield and inductive pickup

Housing:

Aluminium

IP65 (DIN40050)

L = 64mm; W = 58mm; H = 37mm

two cable glands PG7, plastic

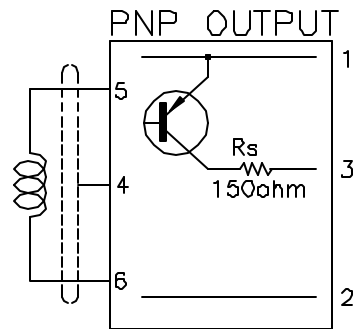
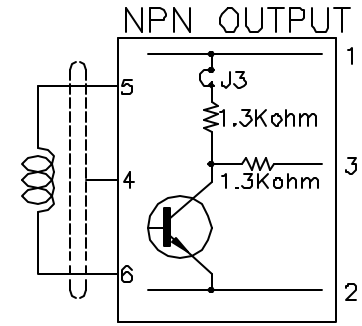
**VIEG Amplifier****Jumper Setting and Terminals**

Version	J3	J4	J5	J6	Terminal
2-Wire	Off	On	Off	Off	1, 2
3-Wire active NPN	On	Off	Off	On	1, 2, 3
3-Wire active PNP	On	Off	On	Off	1, 2, 3
3-Wire passive NPN	Off	Off	Off	On	1, 2, 3

