

FLOW  
TRANSMITTERS



ELECTRONICS FOR  
INSTRUMENTATION

# LLC -BA



## Batch Unit

Manual Rev. 3

Software Versions 1.15 to 1.19

8809 Industrial Drive, Franksville, WI 53126-9337  
Tel: 262-884-9800 Fax: 262-884-9810  
E-Mail: [aw@awcompany.com](mailto:aw@awcompany.com) Web: <http://www.awcompany.com>

# **LLC-BA Batch Unit Manual**

**Rev. 3.0 for LLC-BA Software Version 1.15-1.19**

## **Table of Contents**

Introduction.....	page 3
Features.....	page 3
Technical Data.....	page 3
Relay Contact Ratings.....	page 4
Dimensional Drawings.....	page 4
Input & Output Connections.....	page 5, 6
Typical Connection Diagram.....	page 7
LLC Initial Messages.....	page 8
Display Modes.....	page 8
RATE Display Mode.....	page 8
TO1 Display Mode.....	page 8
TO2 Display Mode.....	page 9
BATCH Status Display Mode.....	page 9
TO1- Reverse Display Mode.....	page 9
Operation/Reset of Totalizers.....	page 9
Totalizer 1.....	page 9
Totalizer 2.....	page 9
Operating Modes.....	page 10
RUN Mode.....	page 10
Batch Operation.....	page 10
Automatic Overrun Compensation...	page 10
Batch Selection/Activation.....	page 11
Batch Input & Output Functions.....	page 11
Batch Function Timing Diagram.....	page 12
Programming the LLC.....	page 13
Programming Label Diagram.....	page 13
Program Mode.....	page 13
Entering/Editing the Variables.....	page 13
Delay.....	page 13
Precut.....	page 14
Gate Time.....	page 14
0-set mA's.....	page 14
KFR-Factor.....	page 15
Decimal Point for KFR.....	page 15
Engineering Units KFR.....	page 16
KFT-Factor.....	page 16
Decimal Point for KFT.....	page 17
Engineering Units KFT.....	page 17
Batch Programming.....	page 18
Limited Warranty Statement.....	page 19



**Frequency Input:** Voltage triggered, 2.00 Volt min. input level, 0 - 4KHz, 10KOhm imp.

**Supply Output:** (to sensor) Approx. 20mA.. at approx. 15VDC

**Relay Outputs:** 2 Form C relay outputs. See Table 1 for contact rating information

**Table 1**

Relay Contact Ratings			
Maximum Switched Power	Resistive Load	DC: 60W 125VA	AC:
	Inductive Load	DC: 30W 60VA	AC:
Maximum Switch Voltage		220V DC, 250V AC	
Maximum Switch Current		2A	
Rated Load	Resistive Load	DC: 30V, 2A 110V, 0.5A	AC:
	Inductive Load	DC: 30V, 1A 110V, 0.3A	AC:

**Dimensional Drawings**

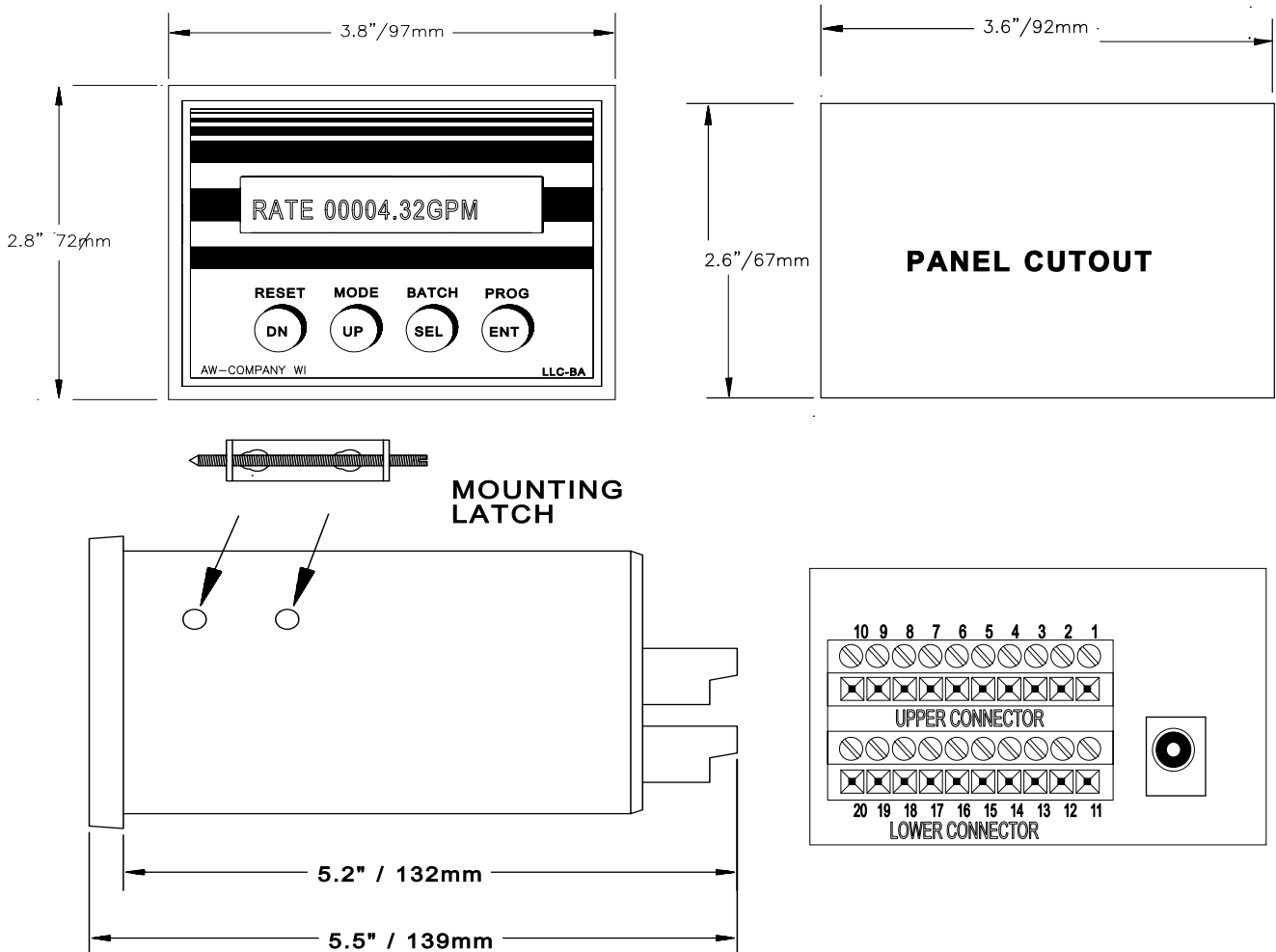

## Input & Output Wiring Connections

All customer connections are made in the back of the unit. Power is delivered to the LLC-BA unit through a plug-in connector from the wall plug type power supply normally supplied with the unit. If necessary, any standard AC wall plug unit providing 12-16VAC/300 mA. or 17-22VDC/300mA. to a standard female plug (2.1mm I.D. x 5.5mm O.D.) may be used.

All other connections are accomplished through the two 10 pin screw terminals that are removable for ease of wiring. These are referred to as the upper and lower connectors. Connection information is labeled on the connectors. See the LLC-BA Connection Diagram on page 7 for connector detail and typical batch application connections.

The connections on the upper connector are as follows:

- |         |   |
|---------|---|
| TERM 1  | +15VDC Power supply for the transmitter. Approx. 15VDC (power supply dependant), approx. 20mA.. max. Source for pull-up resistor if required.   |
| TERM 2  | GROUND (floating), power supply negative for the transmitter.   |
| TERM 3  | SIGNAL frequency input from the transmitter. 0-4KHz , 2 volts minimum, 10KOhm input impedance. A pull-up resistor is required for pickups with a sinking output. Size resistor not to exceed rated output current of pickup. Typical pull-up values range from 2.2Kohm to 5.1Kohm                                   |
| TERM 4  | RUN/PROG Input. Enables RUN-Mode and EXTERNAL functions when connected to GROUND (TERM 2). When open, LLC-BA is in the PROGRAM Mode. This input must be activated with a dry contact!   |
| TERM 5  | REL2COM is the common contact of Relay 2 (Form C). Relay 2 is used in batching applications for control of the high flow solenoid valve in a two valve system with slow start/stop function. See Connection Diagram page 7 for solenoid connection details. See <u>Table 1</u> on page 4 for relay contact ratings. |
| TERM 6  | REL2NC is the normally closed contact for Relay 2.  |
| TERM 7  | REL2NO is the normally open contact for Relay 2.  |
| TERM 8  | REL1COM is the common contact of Relay 1 (Form C). Relay 1 is used in batching applications for control of the low flow solenoid valve in a two valve system with slow start/stop function. See Connection Diagram page 7 for solenoid connection details. See <u>Table 1</u> on page 4 for relay contact ratings.  |
| TERM 9  | REL1NC is the normally closed contact for Relay 1.  |
| TERM 10 | REL1NO is the normally open contact for Relay 1.  |

The connections on the lower connector are as follows:

- TERM 11 VOLTAGE SUPPLY OUTPUT - 15 VDC, 25 mA
- TERM 12 GROUND for Batch External Function Inputs (Inputs 1-4)
- TERM 13 ANALOG OUTPUT SELECT – Connect to TERM 11 to change the function of the analog output from a Batch Progress Signal to a Batch Number Signal. (Software revision 1.18 and above only)
- TERM 14 INPUT1, START/STOP Input (momentary) for batching applications. Start/Stop is accomplished by momentarily connecting INPUT1 (TERM14) to GROUND (TERM 12). Batch start will occur on rising edge of signal as the connection is opened. If input is closed again before the batch total has been reached, stop will occur on falling edge of the signal as the connection is closed. Batch function will resume on the rising edge of the next momentary closure of the STOP/START input. START/STOP function is active in RUN mode.
- TERM 15 INPUT2, BATCH RESET Input (momentary) for batching applications. Batch Reset is accomplished by momentarily connecting INPUT2 (TERM15) to GROUND (TERM 12). When connected, the batch operation will be terminated and the batch totalizing value is reset to zero on the falling edge of the signal as the connection is closed. Reset function is active in RUN mode.
- TERM 16 INPUT3, BATCH SELECT Input (momentary) for batching applications. Used for selection of pre-programmed batch quantities (Batch 1- 9) while in the RUN mode. Batch number is incremented and display indicates batch selected and programmed batch quantity while the input is closed.
- TERM 17 INPUT4, MODE CHANGE Input (momentary) for batching applications. Used to select the display mode while operating in the RUN mode. Display mode is incremented on each closure of the input.
- TERM 18 NO CONNECTION
- TERM 19 mA's (+), Positive of mA's output – this analog output is a batch progress signal or with software revision 1.18 or higher can alternately indicate the currently selected batch number. A Batch Progress Signal directly corresponds with the progress of the batch where 4mA equals zero progress and 20mA is equal to the full batch amount. A Batch Number Signal (Software revision 1.18 and above only) indicates the currently selected batch number in 1 mA increments with 5 – 13mA representing batch numbers 1-9. To assign the output to the Batch Number Signal function it is necessary to wire a jumper to the back of the LLC-BA controller between lower connector terminal 11 and terminal 13.
- TERM 20 mA's (-), Negative of mA's output - see mA's (+) above...

## LLC-BA Typical Connection Diagram

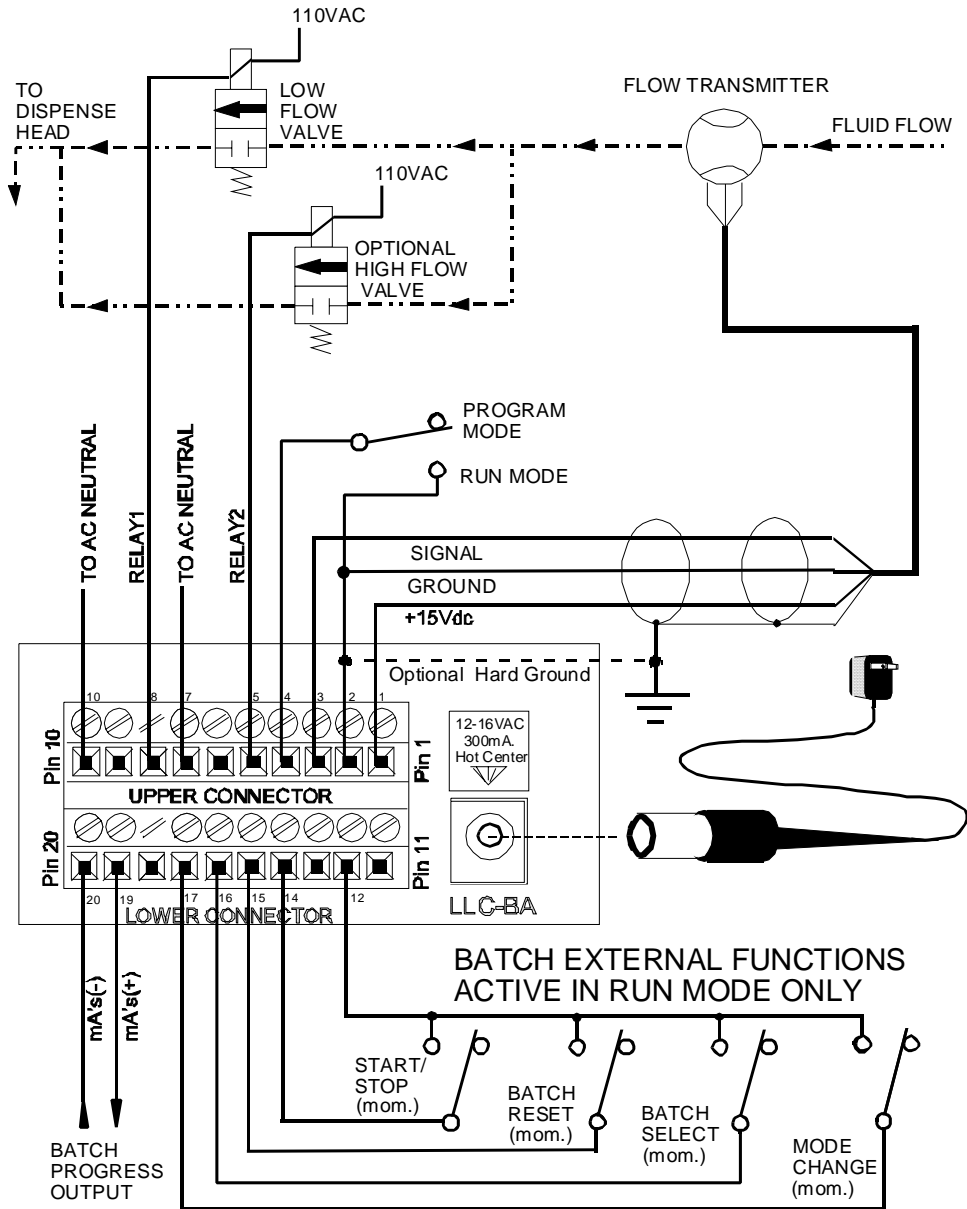

### Input Circuit Detail

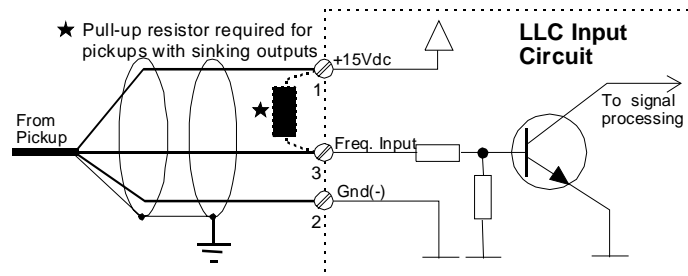

## LLC Initial Messages

The LLC displays some initial messages at power up. After 5 seconds the LLC will briefly display **\*\*\*AW Company\*\*\*** and then the following four variables for approximately 2 seconds each. After these brief displays, the LLC enters the Display Mode.

**VERSION a w 1 . XX** - Indicates the software version installed in the LLC-BA.

**ON COUNT -> 00000XX** – ON count indicator increments each power-on cycle of LLC-BA.

**LEFT MEM%0000100** - Memory life indicator displays % of memory life remaining in 10% increments. The LLC stores programmed variables and retained totalizer values in EEPROM (electrically erasable memory), not a battery. Limits to the number of times memory can be re-written results in a minimum EEPROM life of 5 years with continuous use. This socketed memory IC is field replaceable and replacement memory ICs are available. Care must be used to insert the new memory IC in the exact same orientation as the one removed. Program variables require reprogramming after memory IC change.

**BLK LOC 0000XXX** - Block Location, Used by LLC for EEPROM memory management.

## Display Modes

The Display modes are selected differently in the **PROGRAM** Mode than in the **RUN** Mode. While in the **PROGRAM** Mode, pressing the **[MODE]**-key (UP) changes the display mode from one to the next. When in **RUN** Mode, the display mode can also be changed by pressing the **[MODE]**-key (UP) or by momentarily closing the **MODE CHANGE** input. The LLC retains the selected display mode when powered down and displays the same mode at power up.

**RATE Display Mode** - In the RATE display mode the unit will display the rate in engineering units based on the KFR factor with the decimal point at the selected location and the programmed engineering units at the end. The word RATE appears at the beginning of the display to indicate the selected display mode.

A typical display would be: RATE 00000.34 GPM

**TO1 Display Mode** - In TOTALIZER 1 display mode the LLC displays the total of the currently programmed BATCH in progress. Totalizer 1 is reset to zero on a START input when in RUN mode and will count up to the programmed batch amount. This total is retained by the LLC with the power removed. The display is based on the programmed KFT value, KFT engineering units, and decimal point.

A typical display would be: TO1 000000.0 GAL

**TO2 Display Mode** - In TOTALIZER 2 display mode the LLC displays the current total accumulating in Totalizer 2 (Grand Totalizer). Totalizer 2 accounts for all totalized flow and can only be reset in the PROGRAM mode. This total is retained by the LLC with the power removed. The display is based on the programmed KFT value, KFT engineering units and decimal point.

A typical display would be: TO2 000000.0 GAL

**BATCH Status Display Mode** - The BATCH status display mode indicates the state of the currently selected batch. This display indicates which batch is selected and whether the batch is RUNNING, PAUSED, or DONE. It does not indicate actual batch progress.

A typical display would be: BATCH 1 DONE

**TO1- Display Mode** (REVERSE TOTAL 1) - Displays batch quantity in currently selected batch when START input is closed and counts downward to zero at batch completion in the reverse function of Totalizer 1. Display is reset with Totalizer 1. This total is retained by the LLC with the power removed. The display is based on the programmed KFT value, KFT engineering units, and decimal point.

A typical display would be: TO1- 00000.00 GAL

### **Operation/Reset of Totalizers**

The LLC-01 has two independent totalizers, Totalizer 1 & Totalizer 2. TO1 is dedicated as the batch totalizer. TO2 (Grand Totalizer) keeps a running total of all flow. TO1 & TO2 will rollover at 9999900 regardless of where the decimal is located. Totals are retained by the LLC with the power removed. Retained totals may not reflect the exact totalizer or batch value at the instant the power was removed as variables retained at power down are updated once every 15 seconds.

**Totalizer 1** - Totalizer 1 keeps a total of the currently running batch. In the RUN Mode, TO1 is reset by a momentary closure of the BATCH RESET input. Reset also occurs at the start of each batch as the START input or [BATCH]-key (SEL) is closed and released.

To reset Totalizer 1 in the PROGRAM Mode select the TO1 display mode using the [MODE]-key (UP) and press the [RESET]-key (DN) to reset. TO1 display will be reset to zero by this operation and the TO1- display (inverse TO1) is reset to the quantity of the selected/activated batch.

**Totalizer 2** - Totalizer 2 (Grand Totalizer) totalizes all flow. Totalizer 2 can be reset only when the LLC is in the PROGRAM mode (TERM 4 **not** connected to TERM 2) while in TO2 display mode. TO2 is not reset by any other function.

To reset TO2, select PROGRAM mode by opening the RUN/PROG Input (TERM 4), select the TO2 display mode using the [MODE]-key (UP), and press the [RESET]-key (DN). Totalizer 2 will be reset by this operation and will start accumulating from zero. Use caution whenever in PROGRAM mode as Totalizer 2 can be reset in TO2 Display Mode with only the [RESET]-key!!!

## Operating Modes

The LLC-BA has two operating modes, PROGRAM Mode and RUN Mode. The PROGRAM Mode is used for programming variables and batch quantities or for reset of Totalizer 2. The RUN Mode enables batch operation and the associated inputs.

Operating modes are selected by the RUN/PROG input. When closed, the RUN Mode is enabled. When open, LLC-BA is in the PROGRAM Mode. ( See LLC-BA Connection Diagram.)

### RUN Mode

In the RUN Mode, the external batch functions inputs are active. (See the LLC-BA Connection Diagram.) Two keys are active on the front panel. The [MODE]-key (UP) will change the display and the [BATCH]-key (SEL) can be used to START or STOP a batch.

**Batch Operation** - When a START input or the [BATCH]-key (SEL) is detected, the LLC-BA Batch Unit will activate outputs to initiate flow and then deactivate the outputs when a programmed batch quantity has been reached. One of nine programmable batches can be selected using the Batch Select input. The RELAY outputs control two solenoids with different flow rates to allow for a slow stop/start of the flow. In a typical batch cycle:

RELAY1 Output (low flow solenoid) is activated by the Start Input or the [BATCH]-key (SEL).

After a programmed variable DELAY time, RELAY2 Output (high flow solenoid) is activated producing a combined high flow rate.

RELAY2 Output (high flow solenoid) is deactivated before the batch quantity has been reached by means of the PRECUT variable reducing the flow for a slow stop.

RELAY1 (the low flow solenoid) is de-activated when the programmed batch quantity is reached.

**Automatic Over-run Compensation** - The de-activation of RELAY1 is under the influence of the Automatic Over-run Compensation feature that compensates for a valve or fluid delay in the batch system. For example, if a valve with a .5 second reaction delay is used on a 1000cc. batch, the first quantity delivered will be approx. 1020cc. depending on flow rate.

This over-run is detected by the A.O.C. feature and the LLC-BA anticipates and corrects for the delay on the next batch. This feature is always active and adapting continuously to correct for long term changes in valve and fluid characteristics.

**Batch Selection/Activation** - While in the RUN mode, the BATCH SELECT input is used to select and activate a programmed batch number (Batches 1- 9). Close and hold the input to select a batch #. On each closure, the batch number is incremented by one. The display will read SEL B# 000xx.xx to indicate currently selected batch number and batch quantity. Releasing the input activates the Batch selection and returns the display to the selected Display Mode. Repeat until the desired batch is displayed. Batch numbers with a zero quantity **cannot be** selected/activated. The BATCH SELECT will advance to the next batch with a non-zero quantity. Batches can be selected/activated in the PROGRAM mode using the [BATCH]-key (SEL) to select and the (ENT)-key to activate. See Programming Mode for details.

**Batch Input and Output Functions** - The following inputs and outputs are active in the RUN Mode for batch operation and function as follows:

INPUT1 - The START/STOP is accomplished by momentarily closing INPUT1. Batch START occurs on the rising edge of the signal as the connection is opened. If the input is closed again before the batch total has been reached, STOP will occur on the falling edge of the signal as the connection is closed. The Batch Status display will indicate PAUSED. Batch function will resume on the rising edge of the next momentary closure of the STOP/START input. The [BATCH]-key (SEL) also functions as the STOP/START input in the RUN mode.

INPUT2 - BATCH RESET is accomplished by momentarily closing INPUT2. Batch operation will be terminated and the batch totalizing value is reset to zero on the falling edge of the signal as the connection is closed.

INPUT3 - BATCH SELECT Input (momentary) is used to select and activate a batch number (Batches 1- 9). The active batch number is incremented on the closure. While input is held closed the display will indicate the batch number and batch quantity selected. When the input is opened, the display will return to the selected Display Mode.

INPUT4 - MODE CHANGE Input (momentary) is used to select the Display mode. The display mode is incremented on each momentary closure of the input or will auto-increment through the modes if the input is held closed. Release the input to select the mode when displayed. Display mode can also be changed using the [MODE]-key (UP).

RELAY1- Output (low flow solenoid) is activated by the START Input or [BATCH]-key (SEL) and de-activated when the programmed batch quantity is reached.

RELAY2 - Output (high flow solenoid) is activated after RELAY1 by the DELAY variable, and is deactivated by the PRECUT variable before the batch quantity has been reached.

mA's (+/-) OUTPUT- Active in the RUN mode, this analog output is a batch progress signal or can alternately indicate the currently selected batch number (software revision 1.18 or higher). The mA output is available on terminals 1 & 2 of the main terminal strip.  
**Batch Progress Signal** – Signal directly corresponds with the progress of the batch where 4 mA equals zero progress and 20mA is equal to the full batch amount.

**Batch Number Signal** – mA value indicates batch number in 1mA increments with 5 – 13mA representing batch numbers 1-9. To assign the output to the Batch Number Signal function it is necessary to wire a jumper to the back of the LLC-BA controller between lower connector terminal 11 and terminal 13. (See following connection diagram)

## Changing Analog Output Function

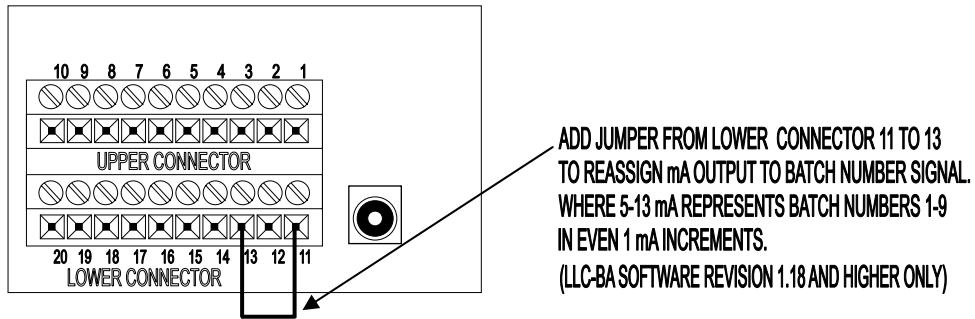

## Batch Function Timing Diagram

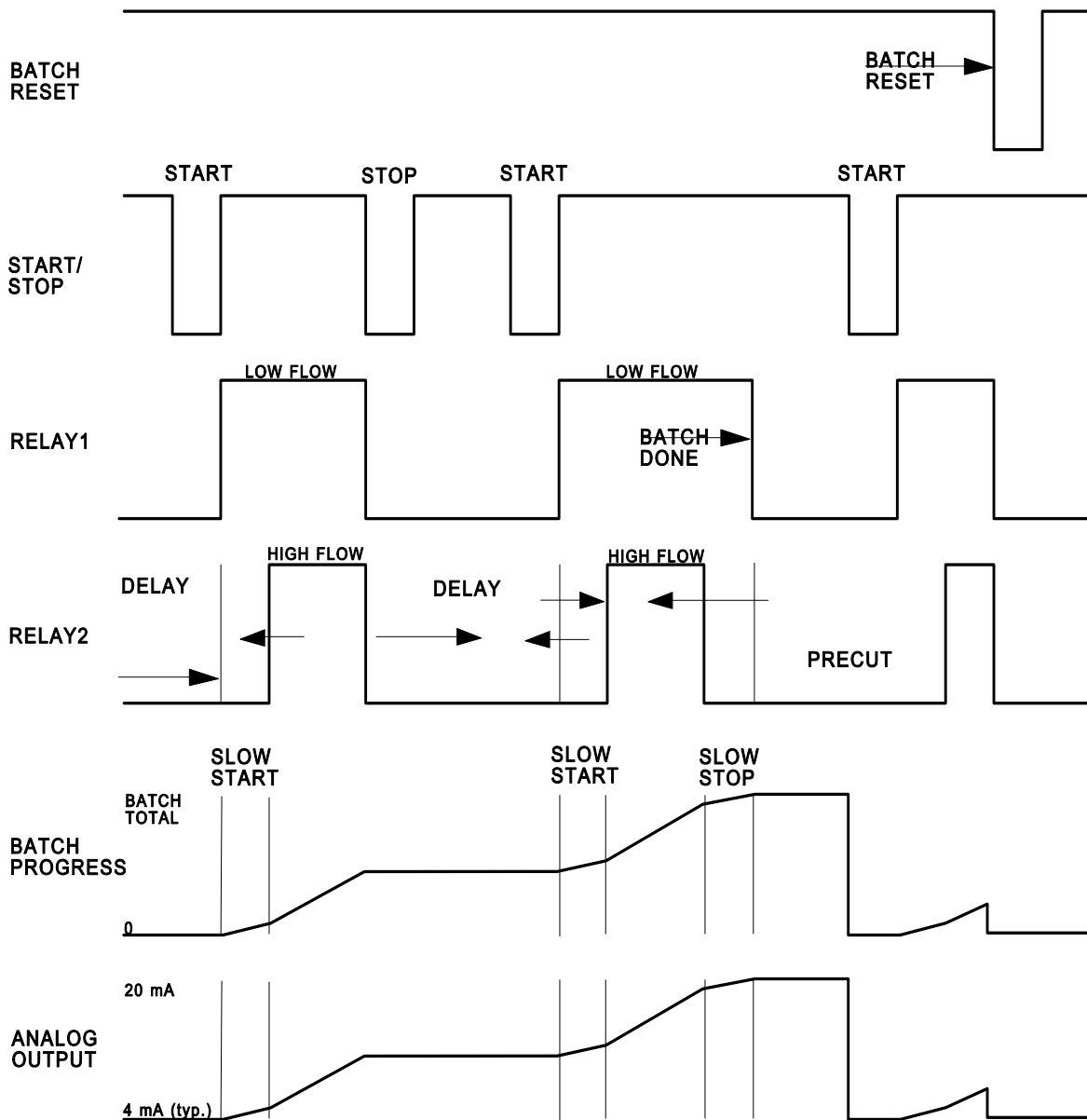





**KFR-factor** - For the LLC to display in a desired engineering unit such as GPM, an appropriate scaling factor must be programmed. This factor is the KFR factor. The KFR is calculated using the K-factor of the transducer being monitored. The K-factor is the number of impulses per engineering unit established by the transducer manufacturer or by a calibration test.

Factory default is 00100.00 (Displays Hertz w/ two decimal places)

To calculate the KFR factor use the following formula:

$$\mathbf{KFR = TIME\ BASE\ CONSTANT / K\ -FACTOR}$$

Where:

- 100 is the time base constant for eng. units per second
- **6000** is the time base constant for **eng. units per minute**
- 360000 is the time base constant for eng. units per hour
- **K-FACTOR** is the average number of pulses per desired eng. unit that the transducer produces.

Remove the insignificant decimals often produced with this calculation as they will result in displays with a misleading level of precision far exceeding the accuracy of the meter. Use a maximum of four digits regardless of decimal point position! Enter KFR without regard to the location of the decimal point in the display. **The desired decimal location is entered in the next procedure.** The largest acceptable number for KFR is 65535.

For example:

A flowmeter has a K-factor 2053.7 imp/Gal and the display should read in Gal/Min.

$$\text{KFR} = 6000 / 2053.57 = 2.921741 \text{ for GPM}$$

292174 is > 65535! 29217 > 4 digits! 2922 is best! Enter 2922 for KFR. For this example, KFR=2.922, the decimal point is set to three decimal places in the next procedure.

Press and hold the **(UP)** or **(DN)**-key to increment or decrement the variable value. To increase the increment or decrement rate, while holding the **(UP)** or **(DN)**-key, press and hold the **(SEL)**-key for medium rate or the **(ENT)**-key for maximum rate. When the desired value is displayed, press the **(ENT)**-key to store the programmed value and advance to the next variable.

NOTE: Always release **(SEL)** or **(ENT)**-key before releasing the **(UP)** or **(DN)**-key or the LLC will proceed to next variable leaving the last variable with an unpredictable value.

**DP for KFR** - This variable selects the location of the decimal point in the KFR factor and the display. This display will always be zeros with a decimal point.

Factory default is 00000.00

Use the **(UP)** or **(DN)**-key to move the decimal point left or right. Press the **(ENT)**-key to store the location and advance to the next variable.



**DP for KFT** - This variable selects the location of the decimal point in the KFT factor and the display. This display will always be zeros with a decimal point.

Factory default is 0000000.

Use the **(UP)** or **(DN)**-key to move the decimal point left or right. Press the **(ENT)**-key to store the location and advance to the next variable.

**Eng'g UNITS KFT** - The desired engineering units for display of rate are entered using up to three programmable characters or letters. Example: Gal

Factory default is pul (for pulses)

The first (left-most) character is programmed/edited first. To choose a letter press the **(UP)** or **(DN)**-key until the desired character or letter appears. Press the **(SEL)**-key to enter the 1st character. Repeat the procedure for the 2nd character and enter with the **(SEL)**-key. Repeat for the 3rd character and store the last entry with the **(ENT)**-key. The LLC will exit to the Display Mode.

This ends the variable programming procedure. The LLC-BA will display the currently selected mode. To initiate batch operation, the PROGRAM/RUN input must be closed (TERM 4 connected to TERM 2) to enter the RUN mode .

## Batch Programming

The LLC-BA must be in the PROGRAM mode to program batch quantities. Nine different batches (1-9) can be programmed. **Program variables must be entered before the batch programming.** Batch quantities are based on the programmed KFT value, KFT engineering units and decimal point.

**NOTE: The maximum value that can be entered for a batch is 429496 regardless of decimal place.** Values greater than 429496 will not be accepted. The more decimal places in the KFT, the smaller the batch that can be programmed. To program larger batches it may be necessary to reduce the number of decimal places in the KFT.

Example:

KFT = 214.38 and the desired batch is 6000.00. Ignoring decimal location the value of 600000 is greater than 429496 and will not be accepted. The solution is to reduce the decimal places of the programmed KFT. With KFT changed to 214.4, batch will be 6000.0. Ignoring decimal location the value of 60000 is now less than 429496 and will be accepted.

To program a batch quantity press the [BATCH]-key (SEL). The display will momentarily read SET BATCH-->1 and then display BATCH1-> 0000000. Pressing the (SEL)-key again will increment the batch number. With a batch selected, press and hold the (UP) or (DN)-key to increment or decrement the batch quantity. To increase the increment or decrement rate, while holding the (UP) or (DN)-key, press and hold the (SEL)-key for medium rate or the (ENT)-key for maximum rate. *NOTE: Always release (SEL) or (ENT)-key before releasing the (UP) or (DN)-key or the LLC may return to the Display Mode leaving the batch quantity with an unpredictable value.* When the desired batch quantity is displayed, press the (ENT)-key to store the programmed value. This will also activate the selected batch number and the LLC unit will return to the Display Mode. To program another Batch quantity, repeat the above procedure. The [BATCH]-key (SEL) and (ENT)-key can be used for batch selection /activation when in the PROGRAM mode. When programming is completed, the PROGRAM/RUN input must be closed (TERM 4 connected to TERM 2) to enter the RUN mode and execute any activated batch.

This ends the batch programming procedure. The LLC-BA will display the currently selected mode. To initiate batch operation, the RUN/ PROGRAM key switch must be set to the horizontal RUN position to enter the RUN mode.

