

Quad-80

Technical Data Guide

Description:

The Quad-80 is an advanced, multi-option sensor used only with the JV-80KL & JV-90KL flow meter. This sensor has several jumper selectable outputs to either multiply the pulse count or to change the amplitude of the pulse. The pulse multiples include 1X, 2X, and 4X. Signal amplitude options are: (supply - 1.4V) or 5V TTL compatible. This sensor also features quadrature output which allows for dual pulse counting by separate data gathering devices or for determining flow direction.

Technical Data

Supply Voltage: 12 - 27Vdc
 Supply Current: 70mA
 Temperature Range: -40F to +185F
 Signal Output: Sourcing, square wave frequency (sinking version available) NPN type.
 Output low \approx 0V
 Output high \approx Supply - 1.4V or 5V (jumper selectable)
 50% duty cycle
 Flow dependent, 1500Hz max.

Signal 1 can be set for X4, X2 or X1 frequency output. Signal 2 can be set for X2 or X1 frequency output. **Quadrature output for flow direction is obtained with signals 1 and 2 set in the X1 or X2 output mode.**

Note: Output signal has in-line diode protection. Once connected to readout, if signal does not go to ground, connect an external resistor, 5K-10Kohm, between input and ground of monitoring equipment.

Jumper settings

Output signal amplitude

J1	Output
A*	Supply - 1.4v
B	+5v

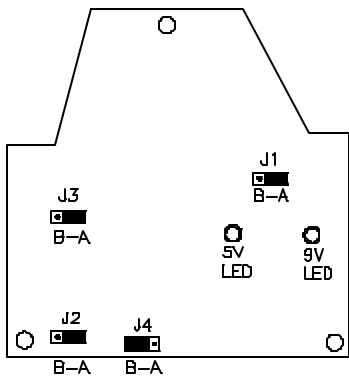

*default

Signal 1 output

J2	J4	Output
A or B	A	X4
A*	B	X2
B	B	Single

Signal 2 output

J3	Output
A*	X2
B	Single

Connector pin out

Red	1	12-27vdc supply
Black	2	Ground
White	3	Signal 1
Green	4	Signal 2

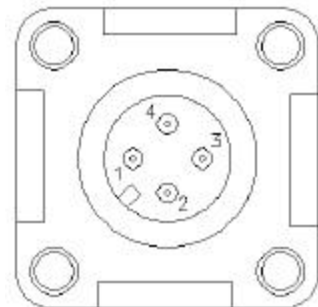

See page 2 for Quad-80 Maintenance Guide

QUAD-80 MAINTENANCE GUIDE

Checking or replacing the Quad-80 sensor is accomplished by the following steps:

Removing Quad-80 sensor:

Loosen the 3 hex bolts (2) using a 9/64" hex key. Carefully lift the sensor housing (1) to expose the two pairs of embedded sensors (3). If the ground wire (5) is attached to the housing, loosen the screw (6) using a 3/32" hex key and remove ground wire from under the screw. To remove embedded sensor elements, remove the screws (4) holding them in place using a 3/32" hex key. The sensors and ground wire may now be carefully removed from the meter body.

Testing Quad-80 sensor:

With embedded sensor elements (3) out of flowmeter housing, connect cable to sensor connector (8). Set jumper J4 on circuit board to A position for 4x output setting. Apply 12-27 vdc power to sensor and while looking at signal 1 output note that output changes while a screw driver or other ferrous object is passed in front of each of the 4 sensor elements, one at a time. If the output does not change when screw driver is passed in front of a sensor element, that particular element is bad and the sensor needs to be replaced.

Installing Quad-80 sensor:

Place O-ring (7) in the O-ring groove. Insert embedded sensor elements (3) into the sensor holes. Replace fastening screws (4) and tighten securely. Fasten ground wire (5) under screw (6) and tighten securely. NOTE: If the ground wire is not going to be used, make sure to tape the spade connector so it will not short against circuit board and also make sure to securely fasten the screw (6) so it will not come loose. Finally, with ground wire and embedded sensor elements fastened, double check that O-ring is completely in O-ring groove and fasten the 3 socket cap screws (2) to secure sensor housing cover (1) onto flowmeter.

