



Küppers Elektromechanik GmbH
Flow Meters

Liebigstraße 2 • D-85757 Karlsfeld • Tel. +49 81 31/59 39 10 • Fax +49 81 31/9 26 04

SRZ 400 Disassembly Instructions

Slacken the M12 Allen screws on the outlet side and unscrew, but keep two opposed screws engaged by 1–2 turns (those green ones shown on the picture) Now remove all others.

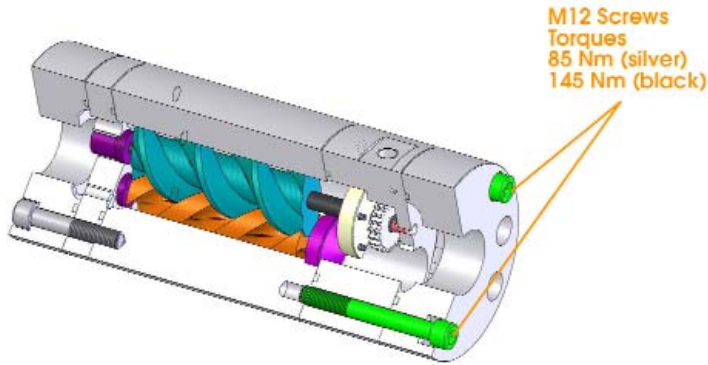

Hold onto the righthand housing and tap the opposing bolts gently with a hammer/mallet to part the housing in parallel direction. Do not attempt to use screwdrivers or similar to split the housing, as otherwise the shafts, bearings and locating pins may be damaged.

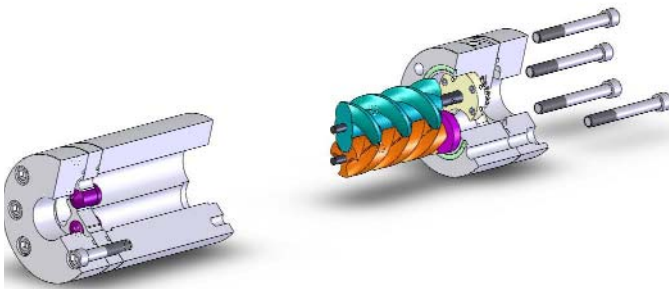

Put the housing in an upright position. Unscrew the four M4 Allen screws to remove the spindle pair. The screws are fixed with Loctite 648. Clean all parts also remove the O-rings and clean the groove before fitting the new O-rings. Please also check the bearing bolt. It must be replaced in case of any damage.

