

TA-3 Sanitary Turbine Flow Meter

Turbine flow meters are affected by upstream and downstream piping configurations. Upstream piping has a pronounced effect on flow meter performance, making it necessary to have ten (10) straight pipe diameter upstream of the turbine flow meter and five (5) pipe diameters downstream of the turbine flow meter. Flow meters should be installed with the arrow marked on the body pointing in the direction of the flow.

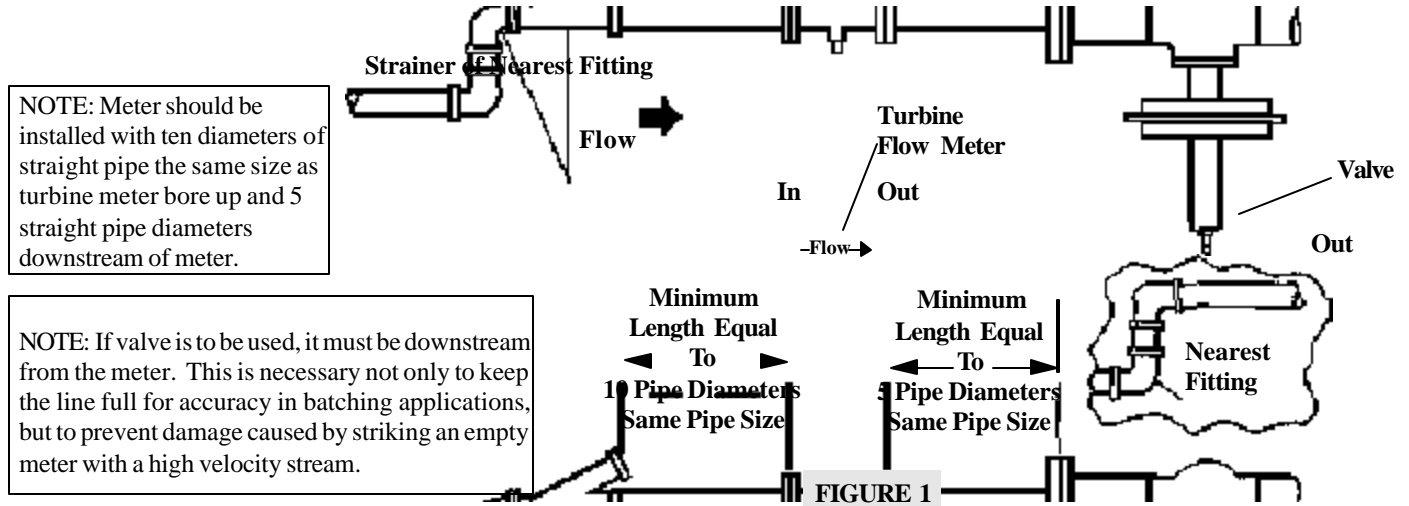

Control valves should always be located downstream from the flow meter. If a line is empty and a valve is opened, the high velocity fluid striking the flow meter can cause severe damage. Air eliminators should be used in cases where gases are flowing in the process stream. Air in the liquid will cause the flow meter rotor to spin at a different rate than the liquid giving incorrect readings.

Spools should be installed in the flow meter position during start-up to prevent damage to the flow meter from solids (welding slag, rust, scale, etc.) in the process liquid.

NOTE: Sleeved bearings used in AW Company flow meters are lubricated with the process fluid. Never spin the flow meter at high speeds with air. Always confirm that the flow line contains fluid at start-up.

The life of the flow meter can be extended by using a mesh filter in the flow line. Table 1 shows the recommended filter for various sizes of flow meters.

Table I

Turbine Flow Meter Size	Mesh Size	Opening Size
1/2"	40	0.015
: "	40	0.015
1 "	40	0.015
1 1/2"	18	0.0386
2 "	14	0.051

Electrical Installation (Figure 2)

Thread the magnetic pickup into the mounting boss located on the top of the flow meter. If the pickup does not have wire leads included, connected the signal cable to the pickup by threading on the keyed connector.

NOTE: HAND TIGHTEN ONLY: USE OF TOOLS TO TIGHTEN THE PICKUP CAN DAMAGE THE FLOW METER AND PICKUP.

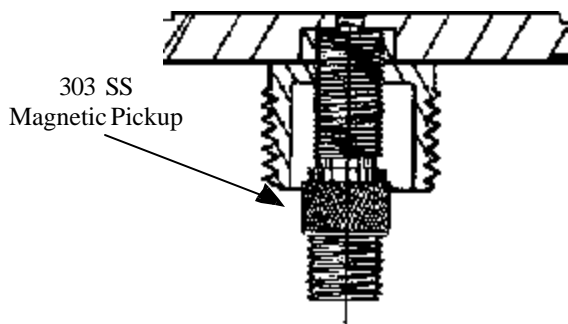
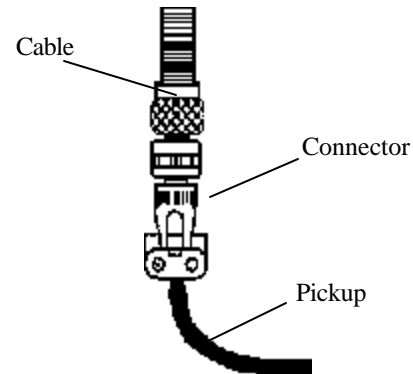

FIGURE 2



Removal of Flow Meter Internals

Cartridge Type Sizes : " through 2" (Figure 3)

The Cartridge Type Turbine Flow Meter utilizes internals assembled into a single part, eliminating the need for the three part internals kit.

Note: This type of internals is not interchangeable with any other body type.

- 1) Remove the magnetic pickup.
- 2) Identify the upstream end of the meter by locating the two grooves visible from the outside of one end.
- 3) Remove the retaining ring from the end of the flow meter identified by the grooves.

Note: There is no retaining ring in the downstream end, (the end where the grooves are NOT visible from the outside of the flow meter).

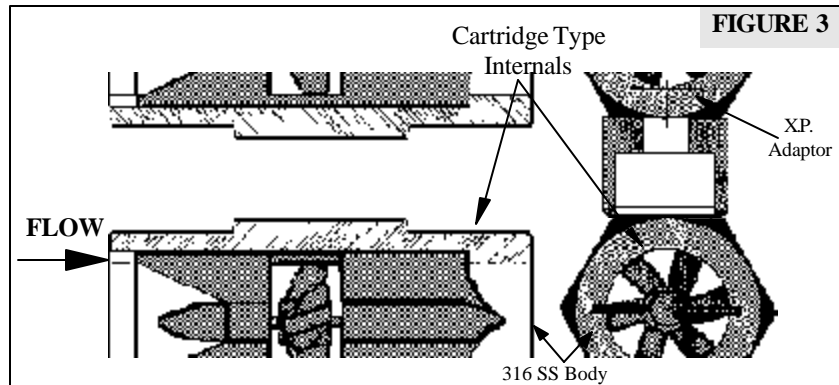

FIGURE 3

- 4) Slide the internals out of the flow meter. It may be necessary to push the internals out by gently applying pressure to the opposite end.
- 5) Inspect the internal bore of the flow meter for defects. The internal surface of the flow meter should be smooth. If the surface is damaged, the flow meter body should be replaced.
- 6) Inspect the internals kit for damage or wear. If it appears to be damaged, replace it with a new internals kit.

Replacement of Flow Meter Internals Cartridge Type Sizes : " through 2"

- 1) Identify the upstream end of the turbine flow meter by locating the two grooves visible from the outside of one end.
- 2) Identify the upstream end of the turbine flow meter internals by locating the end with a cone recessed between two supports forming a "V"
- 3) Insert the end opposite of the recessed cone into the grooves located in the upstream end of the turbine flow meter body.
- 4) Slide the flow meter internals into the turbine flow meter body until it seats firmly against the downstream end.
- 5) Insert the retaining ring into the upstream end of the turbine flow meter pushing it far enough into the flow meter body to engage the retaining ring slot directly above the turbine flow meter internals.
- 6) Install the magnetic pickup.