

# TR & TRG-1100 Turbine Flow Meter

## Instruction Manual

### Operating limitations of the TR & TRG Turbine flow meters

- 1) **Temperature** – Do not subject the meter to temperatures above 325° F (163° C) or below -150° F (-101° C) or the freezing point of the metered liquid. Higher temperature will damage the pickup, and lower temperature will limit the rotation of the rotor.
- 2) **Pressure – 5,000 PSI max:** TRG-11.250-5, TRG-11.375-5, TRG-11.500-5, TRG-11.750-5, TRG-11.750, TRG-11.875, TRG-1110, TRG-1120L **800 PSI max:** TR-1130, TR-40, TR-1160, TR-1180, TR-1100

Note: Consult factory for pressure ratings for units with flanges installed.

**WARNING: Pressure in excess of allowable rating may cause the housing to burst and cause serious personal injury.**

- 3) **Corrosion** – The internal parts of the meter are constructed of stainless steel (316L, 303 & 1.4122) and carbide with nickel binder. Be sure that the operating fluid is compatible with these materials. Incompatible fluids will deteriorate internal parts, and cause the meter to read inaccurately.
- 4) **Pulsation** – Severe pulsation will affect accuracy, and shorten the life of your meter.
- 5) **Vibration & Shock** – Severe mechanical vibration may decrease service life of the meter.
- 6) **Filtration** – A strainer should be installed upstream of the meter if small particles are present (see Table 1 for filtration requirements)

### General Description – TR & TRG Turbine Flow Meters

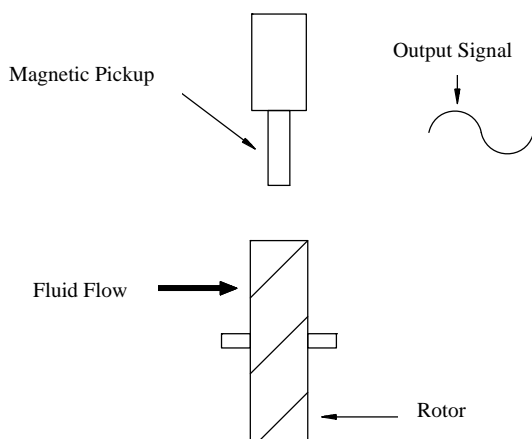

The TR & TRG series of turbine flow meters is designed with a wear resistant rotor assembly to provide trouble free operation and a long service life. Fluid moving through the flow meter causes the rotor to turn at a speed proportional to the flow rate, and as the rotor blades cut through the magnetic field of the pickup, an electronic pulse is generated.

The pulse train is used to represent the actual flow or total amount of fluid passing through the flow meter. The number of electronic pulses generated per unit volume is known as a K-factor. The value is constant over each flow meter's operating range, and is unique to each meter.

# TR & TRG-1100 Turbine Flow Meter

## Instruction Manual

### Installation Instructions: TR & TRG Turbine Flow Meter

Before installation, the flow meter should be checked internally for foreign material and to ensure that the rotor spins freely. Fluid lines should also be cleared of all debris.

**Warning: Make sure that fluid flow has been shut off and pressure in the line released before attempting to install the meter in an existing system.**

The flow meter must be installed with the flow indication arrow, etched on the exterior of the meter body, pointing in the correct direction of flow. The preferred mounting orientation is to have the meter installed in horizontal piping, with the pickup facing upward. However, the meter will function in any position.

The liquid that is to be measured must be free from any large particles that may obstruct rotation of the rotor. If particles are present, a mesh strainer should be installed upstream before operation of the flow meter. (See Table 1)

Table 1

New Model Number	Strainer Mesh
TRG-11.250-5	140 x 140
TRG-11.375-5	140 x 140
TRG-11.500-5	140 x 140
TRG-11.750-5	50 x 50
TRG-11.750	50 x 50
TRG-11.875	50 x 50
TRG-1110	50 x 50
TRG-1120L	50 x 50
TR-1130	10 x 10
TR-1140	10 x 10
TR-1160	4 x 4
TR-1180	4 x 4
TR-1100	4 x 4

**Note: Select appropriate strainer for your turbine model by your turbine part number.**

The preferred plumbing setup is one containing a bypass line (figure 2) that allows meter inspection and repair without interrupting flow. If a bypass line is not utilized, it is important that all control valves be located downstream of the flow meter (figure 3)

It is recommended that a minimum length, equal to ten (10) pipe diameters of straight pipe be installed on the upstream side and five (5) diameters on the downstream side of the flow meter. Otherwise meter accuracy may be affected. Piping should be the same size as the meter bore or the thread port size.

Do not locate the flow meter or the connection cable close to electric motors, transformers, sparking devices, high voltage lines or place connecting cable in conduit with wire furnishing power for such devices. These devices can induce false signals in the flow meter coil or cable, causing the meter to read inaccurately.

# TR & TRG-1100 Turbine Flow Meter

## Instruction Manual

### Operational Start Up: TR & TRG Turbine Flow Meter

The following practices should be observed when installing and starting the meter.

- 1) After meter installation, close the isolation valves, and open the bypass valve. Flow liquid through the bypass valve for sufficient time to eliminate any air or gas in the flow line.

**Caution: Damage can be caused by striking an empty meter with a high velocity flow stream.**

- 2) Open upstream isolating to eliminate hydraulic shock while charging the meter with the liquid. Open the valve to full open.
- 3) Open downstream isolating valve to permit meter to operate.
- 4) Close the bypass valve to a full closed position.
- 5) Adjust the downstream valve to provide the required flow rate through the meter.

NOTE: the downstream valve may be used as a control valve.

If problems arise with the flow meter, consult the Trouble Shooting Guide (Appendix A). If further problems arise, consult the factory. Turbine meter repair kits are also available. See appendix B & C.

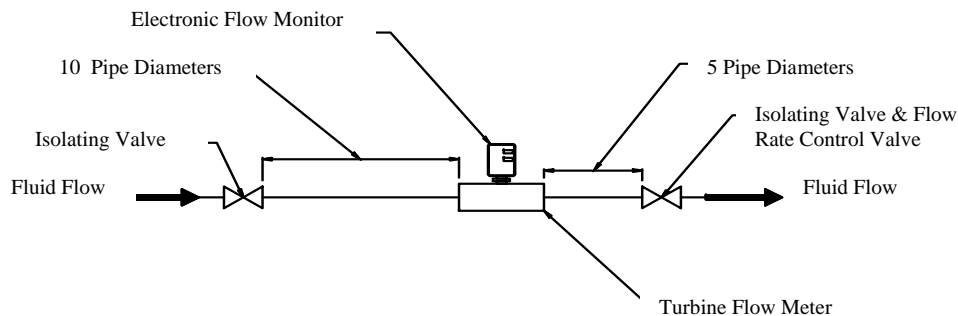
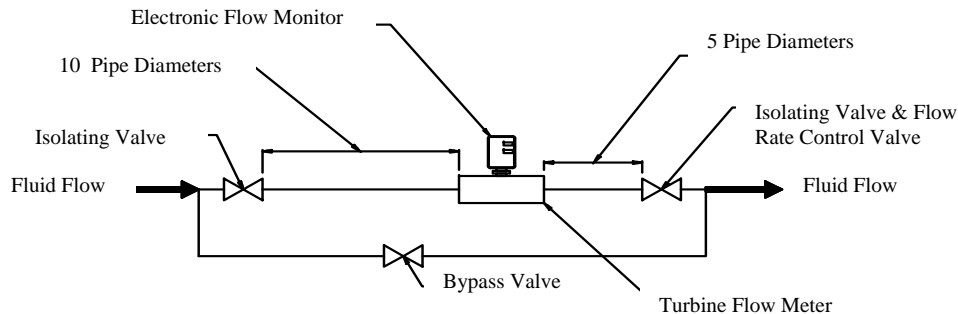

# TR & TRG-1100 Turbine Flow Meter

## Instruction Manual

### Appendix A – Trouble Shooting Guide

Trouble	Possible Cause	Remedy
Meter indicates higher than actual flow rate	Cavitation	Increase back pressure
	Debris on rotor support	Remove debris
	Build up of foreign material on the meter bore	Clean meter
	Gas in liquid	Install gas eliminator ahead of meter
Meter indicates lower than actual flow rate	Debris on rotor	Clean meter and add filter
	Worn bearing	Clean meter, add filter and replace bearing
	Viscosity higher than calibrated	Recalibrate monitor (Appendix A)
Erratic system indication, meter alone works well (remote monitor application only)	Ground loop in shielding	Ground shield one place only. Look for internal electronic instrument ground. Reroute cables away from electrical noise.
Indicator shows flow when shut off	Mechanical vibration causes rotor to oscillate without turning	Isolate meter
No flow indication. Full or partial open position.	Fluid shock, full flow into dry meter or impact caused bearing separation or broken rotor shaft.	Rebuild meter with repair kit and recalibrate monitor. Move to location where meter is full on start-up or add downstream flow control valve.
Erratic indication at low flow, good indication at high flow.	Rotor has foreign material wrapped around it.	Clean meter and add filter.
No flow indication.	Faulty pickup.	Replace pickup.
System works perfect, except indicates lower flow over entire range.	Bypass flow, leak.	Repair bypass valves, or faulty solenoid valves.
Meter indicating high flow, upstream piping at meter smaller than meter bore.	Fluid jet impingement on rotor.	Change piping.
Opposite affects as above.	Viscosity lower than calibrated.	Change temperature, change fluid or recalibrate meter.

# TR & TRG-1100 Turbine Flow Meter Instruction Manual

## Appendix B Repair Kit Information for TRG turbines Line Sizes 1/8" up to 2"

Flow Meter Size	Repair kit fits meter model #	Repair kit part number
1/8"	TRG-11.250-5	TRG-KIT-11.250
1/4"	TRG-11.375-5	TRG-KIT-11.75-5
3/8"	TRG-11.500-5	TRG-KIT-11.500-5
1/2"	TRG-11.750-5	TRG-KIT-11.750-5
5/8"	TRG-11.750	TRG-KIT-11.750
7/8"	TRG-11.875	TRG-KIT-11.875
1-1/2"	TRG-1110	TRG-KIT-1110
2"	TRG-1120L	TRG-KIT-1120L

**Caution: Always reassemble rotor supports. Rotor and meter body are all marked with flow arrows, which must all point in the same direction.**

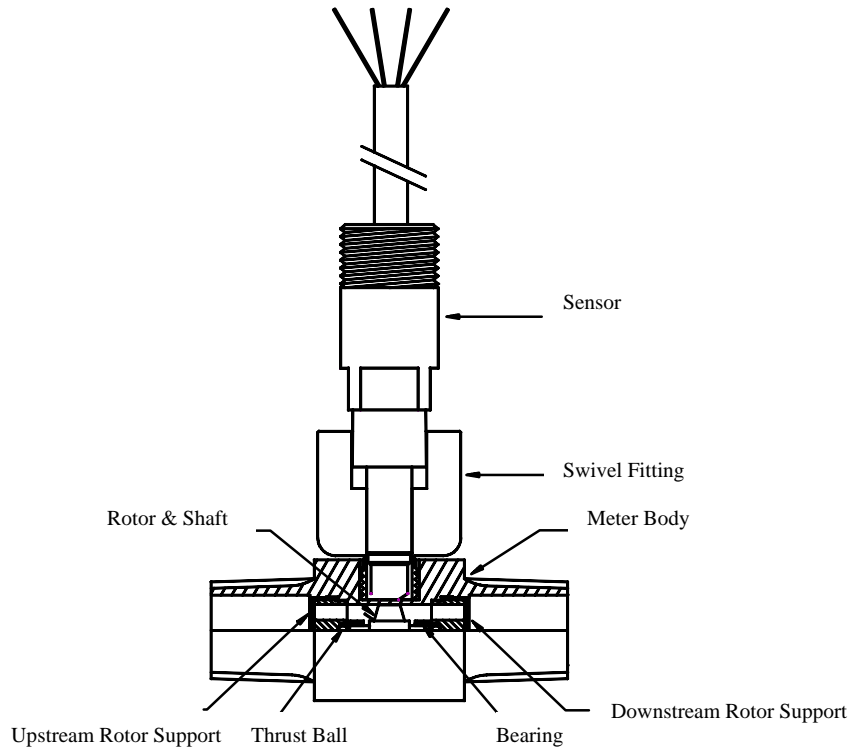

# TR & TRG-1100 Turbine Flow Meter Instruction Manual

## Appendix C Repair Kit information for TR Series

Lines sizes 3/8" up to 10"

Flow Meter Size	Repair kit fits meter model #	Repair kit part number
3/8"	TR-11.375	TR-103
1/2"	TR-11.500	TR-105
3/4"	TR-11.750	TR-108
7/8"	TR-11.875	TR-109
1"	TR-1110	TR-112
1-1/2"	TR-1115	TR-116
2"	TR-1120	TR-120
2" Low	TR-1120L	TR-116
3"	TR-1130	TR-131
4"	TR-1140	TR-141
6"	TR-1160	TR-161
8"	TR-1180	TR-181
10"	TR-1200	TR-200

**Caution: Always reassemble rotor supports. Rotor and meter body are all marked with flow arrows, which must all point in the same direction.**

