

Lake Monitors Hydraulic System Test Analyzers

FOR 3/8" – 1-1/2" PIPE SIZES

STYLE K Flow & Pressure

STYLE T Flow, Pressure & Temperature

Used to diagnose faults in hydraulic circuits, determine horsepower and test for component wear such as hydraulic valve and cylinder leakage.

A COMPLETE TROUBLESHOOTING SYSTEM

The analyzer consists of a flow meter, glycerine-filled pressure gauge (Style "K"), bi-metal temperature gauge/dry pressure gauge (Style "T") and a precision needle-type load valve. A comprehensive operator's manual describes testing of various system components.

MATERIALS OF CONSTRUCTION

Kits offer choice of flow meters in aluminum for pressure up to 3000 PSIG or stainless steel for pressures up to 5000 PSIG. All stainless steel #303/304 kits available for pressure up to 6000 PSIG. *Contact Lake for more information.*

PLANNED COMPONENT REPAIRS

This system analyzer can be part of a predictive maintenance program, allowing strategized pump, valve, motor and cylinder rebuilding.

COMPACT AND RUGGED

The complete hydraulic system test analyzer is small enough to fit in a tool box and built to withstand rigorous industrial use.

NON-ELECTRICAL

Without batteries to fail or other electrical power connections to make, this system will provide a life-time of simple and reliable operation.

METRIC AND US /STANDARD MEASURING RANGES

These multi-measurement analyzers simultaneously measure flow in GPM and LPM, pressure in PSIG and Bar, and temperature in degrees F and C.

UNRESTRICTED MOUNTING

Accurate measurements can be taken in any mounting orientation, without the straight pipe required with other analyzer systems.

SYSTEM PROBLEMS PIN-POINTED

The hydraulic system analyzer and comprehensive troubleshooting manual will save time and money by testing discrete components within the system, eliminating trial and error approaches.

REVERSE FLOW OPTION AVAILABLE

Built-in reverse bypass mechanism prevents potential damage from mis-installation or backflow.



Hydraulics Diagnostics Tool Kit Applications

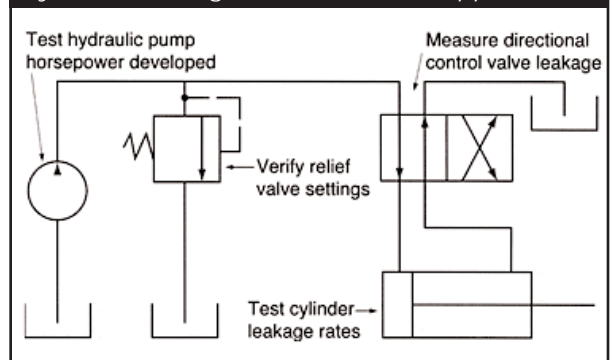

Hydraulic System Test Analyzers

MATERIALS OF CONSTRUCTION

WETTED COMPONENTS		NON-WETTED COMPONENTS	
COMPONENT	MATERIALS	COMPONENT	MATERIALS
High-pressure casing, end ports and tapered shaft	Aluminum (3000 PSIG version) Stainless Steel (5000 PSIG version)	Window Tube	Polycarbonate
Seals	Buna-N (STD), Viton, EPR, Neoprene optional	Window TubeSeals	Buna-N
Transfer Magnet	Teflon [®] coated Alnico	Gauge Window	Acrylic
Floating Orifice Disk	Stainless Steel		
All other internal parts	Stainless Steel		
Needle Valve	Carbon Steel (Stainless optional)		
Gauge	Brass and Stainless Steel		

Teflon is a registered trademark of DuPont de Nemours & Co.

PERFORMANCE

Measuring Accuracy:	Flow: $\pm 4\%$ of full-scale ($\pm 2.5\%$ in center third of measuring range); Pressure: $\pm 2.5\%$ of full-scale; Temperature: $\pm 2.5\%$ of full-scale
Repeatability:	$\pm 1\%$ of full-scale – all measurements
Measuring Range:	Flow: 0.05 – 150 GPM (0.2-560 LPM) See guide to standard meters for specific ranges; Temperature: 0–250°F (-20–120°C)
Maximum Operating Pressure:	Aluminum meters: 3000 PSIG (200 Bar); Stainless Steel Meters: 5000 PSIG (340 Bar); All stainless version: 6000 PSIG (410 Bar)
Maximum Operating Temperature:	240°F (116°C)
Standard Calibration Fluids:	Oil meters: DTE 25 [®] @ 110°F (43°C), 0.873 sg
Filtration Requirements:	74 micron filter or 200 mesh screen minimum

DTE 25 is a registered trademark of Exxon Mobil.

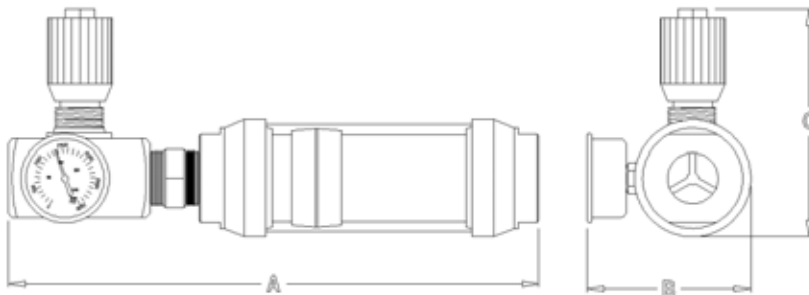

MECHANICAL SIZE CODE

DIM	SERIES 3	SERIES 3	SERIES 4	SERIES 4	SERIES 5	SERIES 5
Port Sizes	3/8" NPTF	1/2" NPTF	3/4" NPTF	1" NPTF	1-1/4" NPTF	1-1/2" NPTF
A	9-1/2" (242mm)	10-1/8" (257mm)	11-1/8" (283mm)	12-1/2" (318mm)	15-5/8" (397mm)	15-25/32" (401mm)
B (K-Style)	3-1/2" (89mm)	3-9/16" (91mm)	4-1/16" (103mm)	4-1/8" (105mm)	4-7/8" (124mm)	5-3/32" (130mm)
B (T-Style)	3-7/32" (82mm)	3-5/16" (85mm)	3-25/32" (96mm)	3-7/8" (99mm)	4-5/8" (118mm)	4-13/16" (123mm)
C	3-5/8" (92mm)	4-3/16" (107mm)	4-31/32" (127mm)	6-1/4" (159mm)	7" (178mm)	7-3/16" (183mm)
DIM	SERIES 3	SERIES 3	SERIES 4	SERIES 4	SERIES 5	SERIES 5
Port Sizes	#6 SAE	#8 SAE	#12 SAE	#16 SAE	#20 SAE	#24 SAE
A	9-7/16" (240mm)	9-9/16" (243mm)	11-3/32" (282mm)	12-9/32" (312mm)	15-3/8" (391mm)	15-3/8" (391mm)
B (K-Style)	3-1/2" (89mm)	3-19/32" (92mm)	4-1/16" (103mm)	4-1/8" (105mm)	4-29/32" (127mm)	5-3/32" (130mm)
B (T-Style)	3-7/32" (82mm)	3-5/16" (85mm)	3-25/32" (96mm)	3-7/8" (99mm)	4-5/8" (118mm)	5-13/16" (148mm)
C	3-5/8" (92mm)	4-3/16" (107mm)	4-31/32" (127mm)	6-1/4" (159mm)	7" (178mm)	7-3/16" (183mm)



www.lakemonitors.com

AW-LAKE COMPANY
 A TASI Group Company
 8809 Industrial Dr., Franksville, WI 53126
 262.884.9800 / Fax: 262.884.9810
 800.850.6110